

ACTIV FUSE.

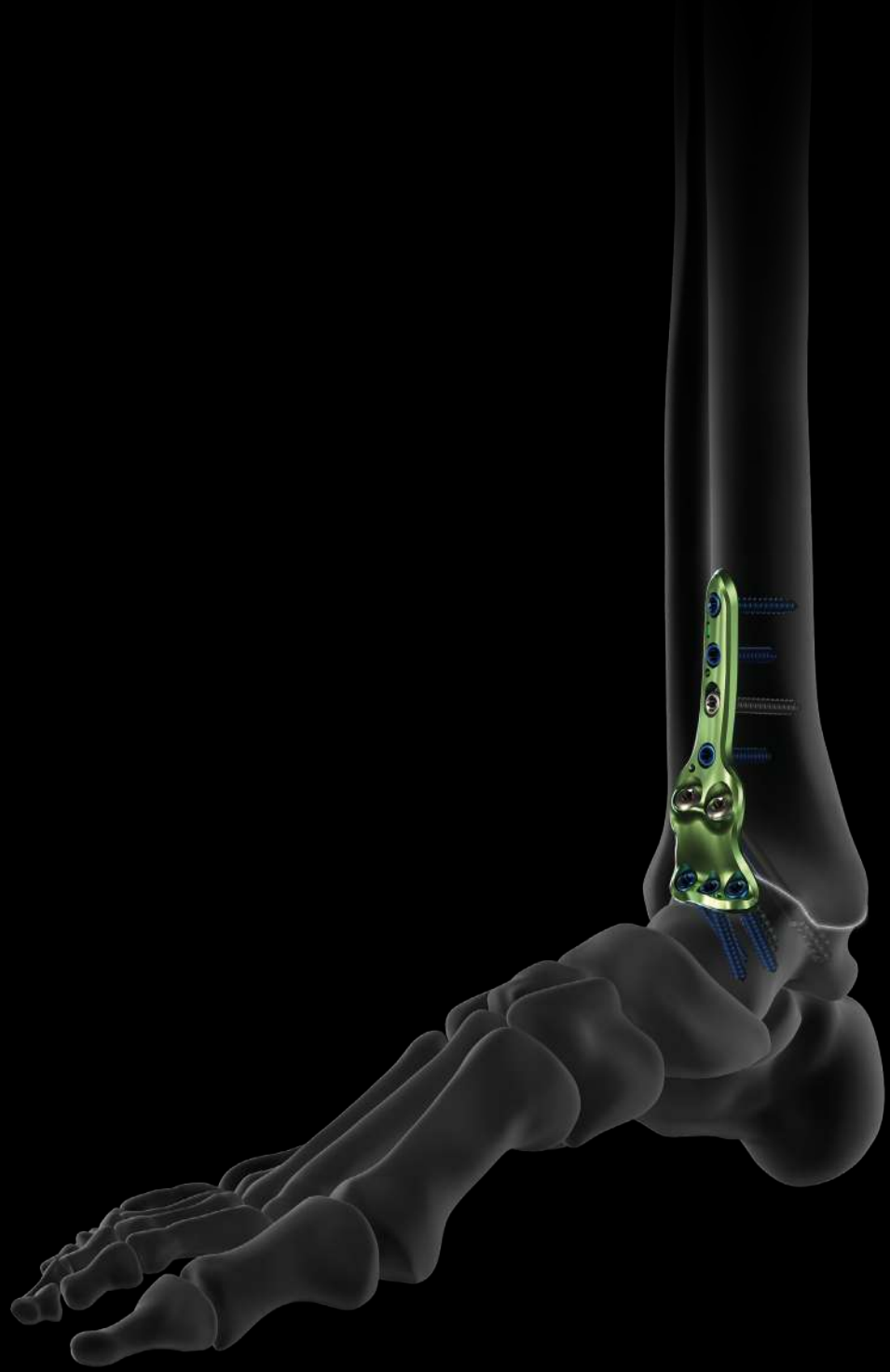

ANKLE
FUSION





Activ Fuse.

ANKLE FUSION

Intended purpose :

The implants of the Activ Fuse range are intended for bone reconstruction of the ankle joint in adults including fractures fixation and arthrodeses of the ankle, distal tibia, talus, and calcaneus.

Contra-indications :

- Pregnancy.
- Acute or chronic local or systemic infections.
- Allergy to one of the materials used or sensitivity to foreign bodies.

A comprehensive range of plates.

ANTERIOR APPROACH

ANTERIOR PLATES

- The five distal holes of the size 1 plate maximize fixation possibilities in the talus.
- Size 0 plate with a single row of screws in the talus suitable for short talar neck.
- Short plate suitable with less invasive approach than standard plates.
- The two transarticular screws going through the ankle, and subtalar joint if need be, allow compression of tibiotalar (TT) or tibio-talo-calcaneal (TTC) joints.

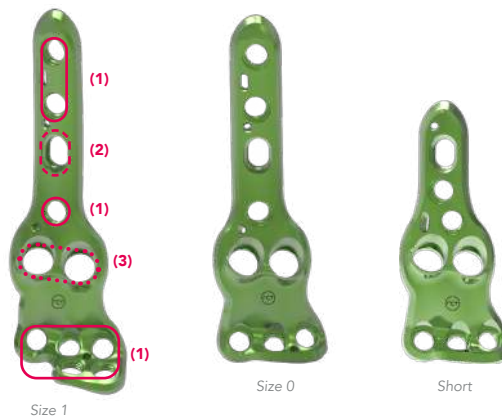

- Ø4.0 mm locking holes ⁽¹⁾
- Ø4.0 mm oblong hole ⁽²⁾
- Ø6.5 mm non-locking holes for TT or TTC arthrodesis ⁽³⁾

ANTERIOR NARROW PLATE

- The anterior narrow plate is positioned on the anterior part of the ankle.

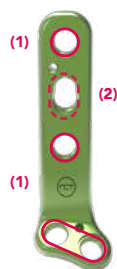

- Ø4.0 mm locking holes ⁽¹⁾
- Ø4.0 mm locking ramp oblong hole ⁽²⁾



Ø6.5 mm cannulated screws available in the Activ Screw range.

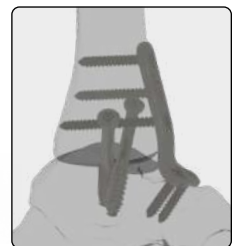

N.B: For locking holes, Newclip Technics recommends the use of locking screws. However, if need be, the use of non-locking screws in locking holes is left to the surgeon's discretion.

Remark : This plate is intended to always be used as a support fixation for ankle arthrodesis in combination with the Ø6.5 mm screws of the Activ Screw range. In no circumstances should the plate be used alone. Please refer to the Activ Screw brochure.

ANTEROLATERAL APPROACH

ANTEROLATERAL PLATES

- The anterolateral plates are designed for a lateral approach.
- The five distal holes of the plates maximize fixation possibilities in the talus.
- The two transarticular screws going through the ankle, and subtalar joint if need be, allow compression of TT or TTC joints.
- Optional lateral support allowing additional stability for TTC fusion.

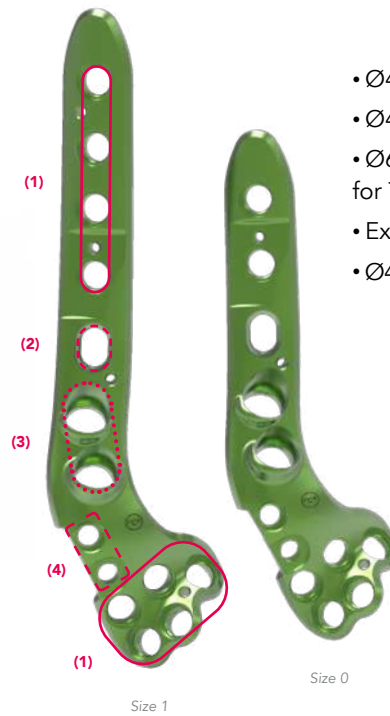

- Ø4.0 mm locking holes (1)
- Ø4.0 mm oblong hole (2)
- Ø6.5 mm non-locking holes for TT or TTC arthrodesis (3)
- Extension fixing system (4)
- Ø4.0 mm non-locking hole (5)

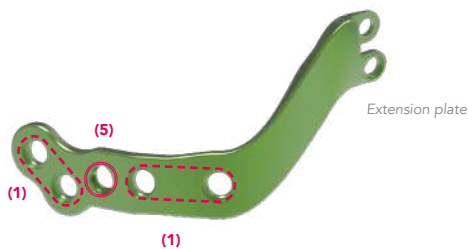

POSTERIOR APPROACH

TT PLATE

- The three distal holes of the plate maximize fixation possibilities in the talus.
- The transarticular screw going through the ankle allows compression of TT joint.

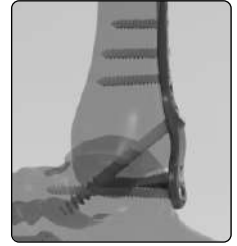
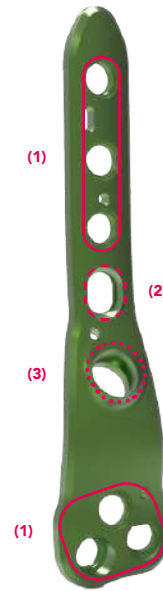

- Ø4.0 mm locking holes ⁽¹⁾
- Ø4.0 mm oblong hole ⁽²⁾
- Ø6.5 mm non-locking holes for TT arthrodesis ⁽³⁾

TTC PLATES

- Two designs adapted to different anatomies: standard or straight plate.
- The five distal holes of the plate maximize fixation possibilities in the talus and the calcaneum.
- The transarticular screw going through the ankle and subtalar joint allows compression of TTC joints.

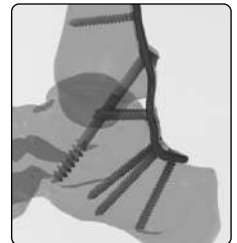
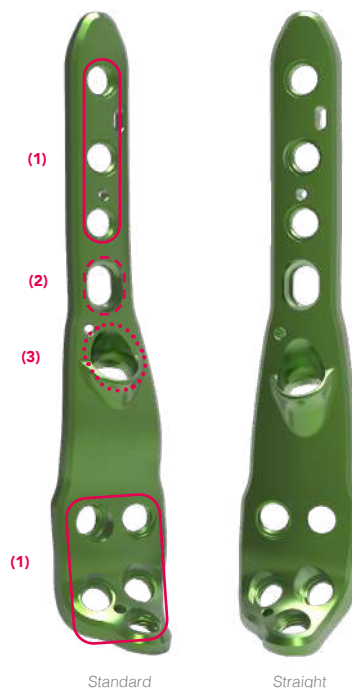

- Ø4.0 mm locking holes ⁽¹⁾
- Ø4.0 mm oblong hole ⁽²⁾
- Ø6.5 mm non-locking holes for TTC arthrodesis ⁽³⁾

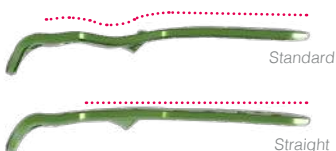

Technical features.

PRECONTOURED IMPLANTS

The design of these implants is the result of a proprietary state-of-the-art mapping technology to establish the optimized congruence between the plate and the bone.



LOCKING SYSTEM

- Features:
 - The screw head is stopped in the hole by its cap, ensuring the locking,
 - The screw head is buried in the plate ^(a),
 - Plates and screws are all made of titanium alloy.
- Coaptation of both profiles when locking.

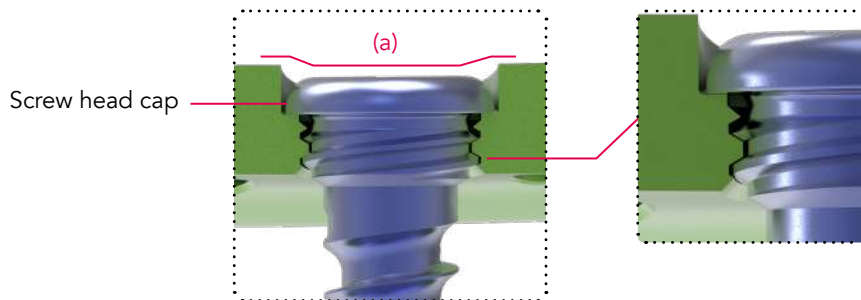

The threads under the screw head and inside the hole have strictly the same characteristics

- Two types of Ø4.0 mm screws: **locking** (SOT4.0LxD) and **non-locking screws** (CT4.0LxD)
- Two types of transarticular screws for **TT (tibiotalar)** and **TTC (tibio-talo-calcaneal)** arthrodeses:
 - **Compression screws** (QT6.5LxD): partially threaded for lag effect
 - **Neutralization screws** (CT6.5LxD): fully threaded for stabilization
- **Hexalobular screw recess T20*** for all the screws enabling torque transmission.



* The fixation screws of the anterolateral plate extension have a T8 screw recess.

ANTERIOR NARROW PLATE SPECIFIC FIXATIONS

- Locking ramp oblong hole
 - The ramp oblong hole allows a guided axial compression by using the screw/plate interface.
 -  In order to achieve compression, Ø4.0 mm non-locking screws (CT4.0LxxD) can be used. They must be inserted in the proximal part of the ramp oblong hole.
 - If no additional compression is required, a Ø4.0 mm locking screw (SOT4.0LxxD) can be inserted into the distal part of the hole. To do so, use the Ø3.0 mm threaded guide gauge (ANC847).

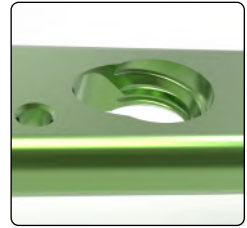

- Dynamic compression

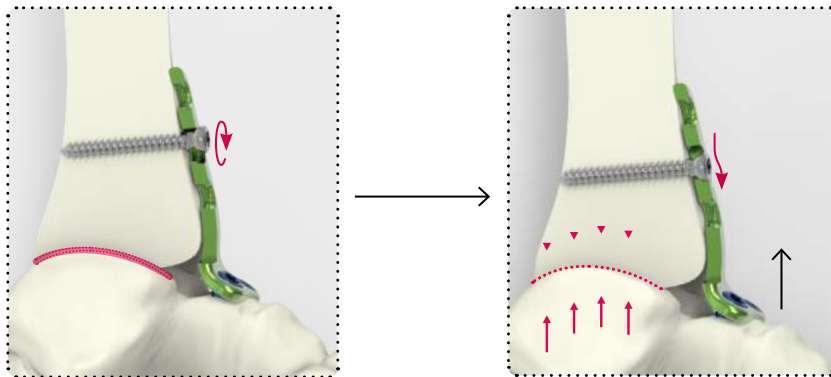

- Locked fixation

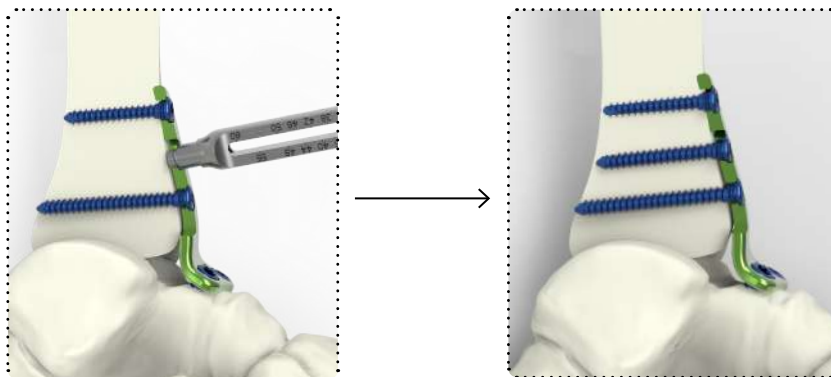

SPECIFIC MEASUREMENT AND LAG EFFECT

LENGTH MEASUREMENT: ONE DRILL, TWO MEASURES

- When inserting a $\varnothing 4.0$ mm screw (CT4.0LxD or SOT4.0LxD) into a locking hole or non-locking hole, in order to determine the appropriate screw length, use the **$\varnothing 3.0$ mm drill bit marking** (ANC852) and the threaded guide gauge (ANC847).

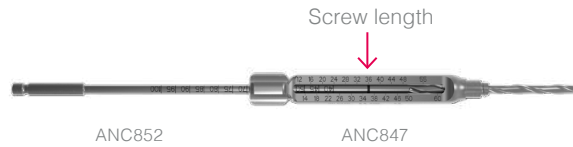

- When inserting a $\varnothing 6.5$ mm lag screw (QT6.5LxD), in order to determine the appropriate screw length, use the **$\varnothing 3.0$ mm drill bit graduations** (ANC852) and read directly the required length at the rear of the $\varnothing 3.0$ mm drill guide (ANC855).



LAG EFFECT

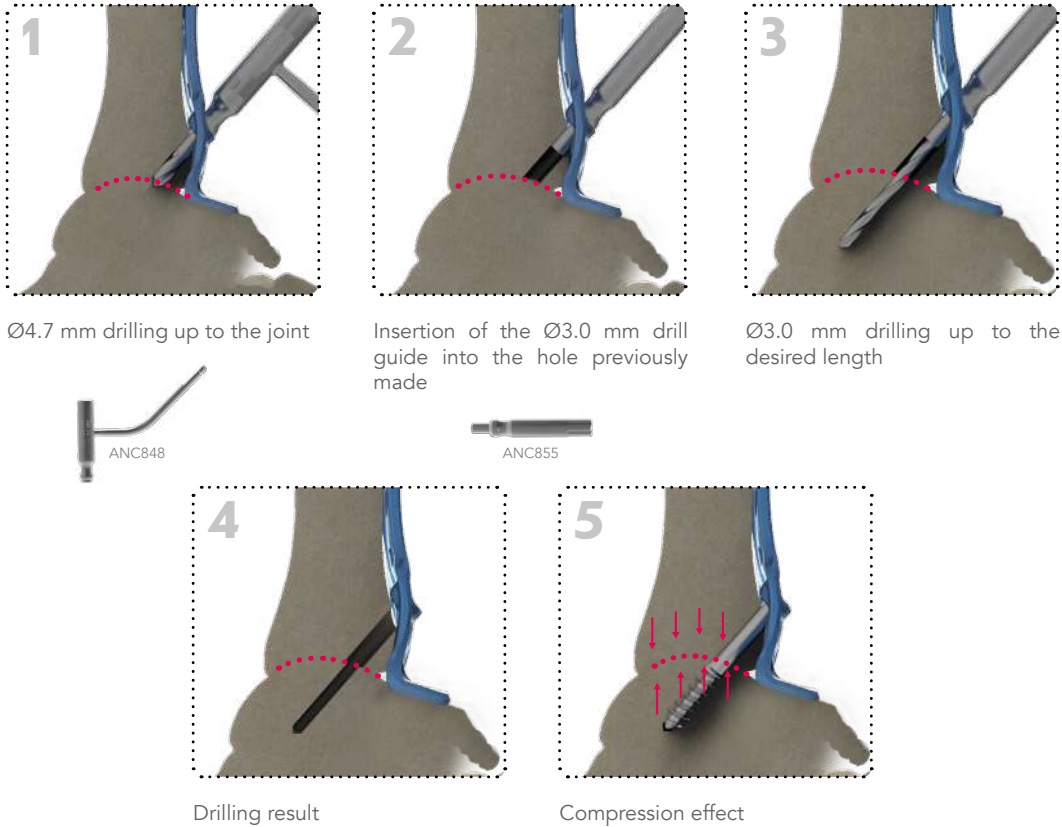

Surgical technique.

ANTEROLATERAL PLATE

Example of the anterolateral plate size 1 (RATDB1). The surgical technique will be identical for the other plates of the range.

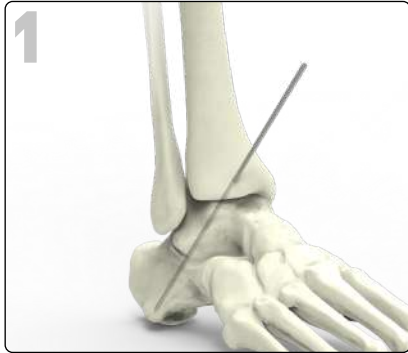

1 Prepare joint surfaces and stabilize the ankle by inserting one or two Ø2.5 mm pins (33.0225.180) through the joint.

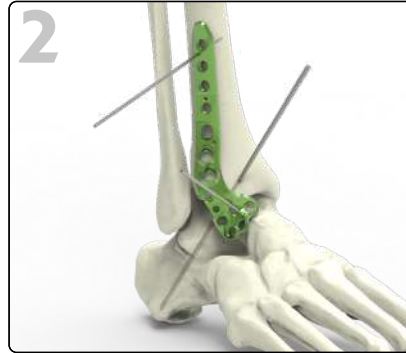

2 Position and stabilize the plate by using the Ø1.6 mm pins (33.0216.150).

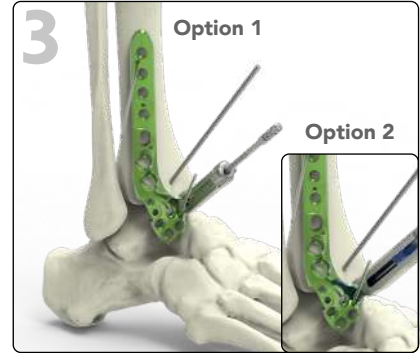

3 Lock the Ø3.0 mm threaded guide gauge (ANC847) into one of the distal locking holes and drill using the Ø3.0 mm drill bit (ANC852). Then measure the corresponding screw length.

Option 1: Determine the screw length using the Ø3.0 mm threaded guide gauge (ANC847) and the Ø3.0 mm drill bit marking (ANC852).

Option 2: Determine the screw length using the length gauge (ANC856).



4 Insert a Ø4.0 mm locking screw (SOT4.0LxxD) using the T20 screwdriver (ANC854).

Repeat the previous steps at least once and until the plate is stable on the talus bone.

Remove the distal Ø1.6 mm pin (33.0216.150).

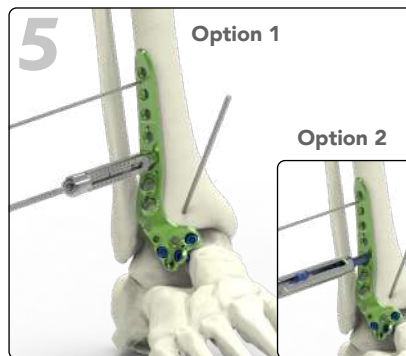

5 Position the threaded guide gauge (ANC847) into the **proximal part of the oblong hole**. Drill using the Ø3.0 mm drill bit (ANC852) and measure the corresponding screw length.

Option 1: Determine the screw length using the Ø3.0 mm threaded guide gauge (ANC847) and the Ø3.0 mm drill bit marking (ANC852).

Option 2: Determine the screw length using the length gauge (ANC856).

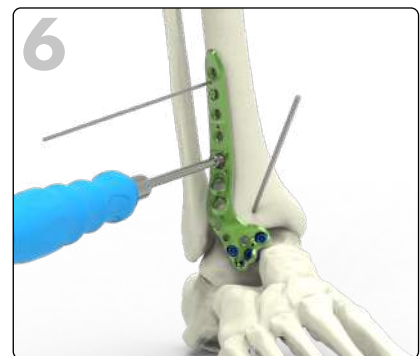

6 Insert a Ø4.0 mm standard cortical screw (CT4.0LxxD) using the T20 screwdriver (ANC854).

7- ALTERNATIVE 1 : FIXATION WITH COMPRESSION SCREW

(Ø6.5 mm lag screw: QT6.5LxxD)



Insert the Ø4.7 mm bent drill guide (ANC848) into one of the transarticular holes and drill using the Ø4.7 mm drill bit (ANC851) **up to the joint**. Remove both the drill bit and the drill guide.

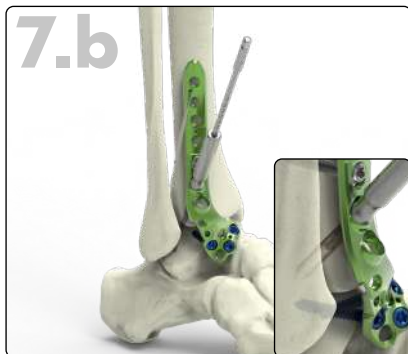

In order to achieve a lag effect, insert the Ø3.0 mm drill guide (ANC855) into the same transarticular hole and make sure the drill guide is inserted into the previously drilled hole. Drill to the desired depth using the Ø3.0 mm drill bit (ANC852). Determine the screw length at the rear of the Ø3.0 mm drill guide (ANC855) using the graduations on the Ø3.0 mm drill bit (ANC852) (see specific measurement). It is also possible to use the length gauge for Ø6.5 mm screws (ANC853).



Remove the pins. Insert a Ø6.5 mm lag screw (QT6.5LxxD) using the T20 screwdriver (ANC854).

N.B: If widening of the cortex is necessary, use the Ø6.0 mm countersink (ANC845) before Ø6.5 mm screw insertion.

Remark: Before the Ø6.5 mm lag screw insertion, slightly release the Ø4.0 mm standard cortical screw in the oblong hole to optimize the compression.

Then retighten the Ø4.0 mm standard cortical screw when the desired compression is reached.

7- ALTERNATIVE 2 : FIXATION WITH NEUTRALIZATION SCREW

(Ø6.5 mm non-locking screw: CT6.5LxxD)



Insert the Ø4.7 mm bent drill guide (ANC848) into one of the transarticular holes and drill using the Ø4.7 mm drill bit (ANC851).

Determine the screw length at the rear of the Ø4.7 mm bent drill guide (ANC848).

It is also possible to use the length gauge for Ø6.5 mm screws (ANC853).



Insert the Ø6.5 mm non-locking screw (CT6.5LxxD) using the T20 screwdriver (ANC854).

N.B: If widening of the cortex is necessary, use the Ø6.0 mm countersink (ANC845) before Ø6.5 mm screw insertion.

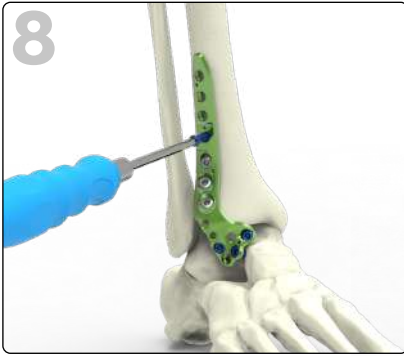

FINAL RESULT.



Insert the remaining distal and proximal Ø4.0 mm locking screws (SOT4.0LxxD) according to steps 3 and 4.

N.B: To insert the lateral extension, you can refer to the section below.

OPTION : CALCANEAL LATERAL EXTENSION (STEP 1/2)

Surgical approaches are the responsibility of the health professional. The recommendations in this document are provided for informational purposes only. Each surgeon must evaluate the relevance of the procedures based on his training and experience.

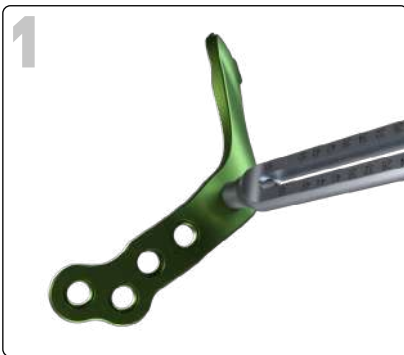

Lock the Ø3.0 mm threaded guide gauge (ANC847) in the most anterior locking hole to manipulate the plate.

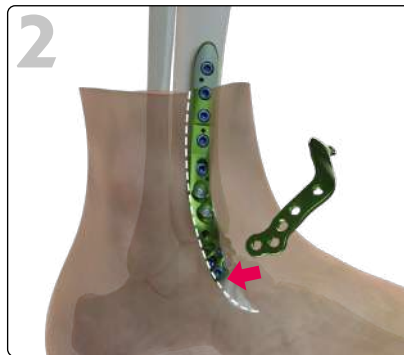

Insert the assembly through the existing incision.

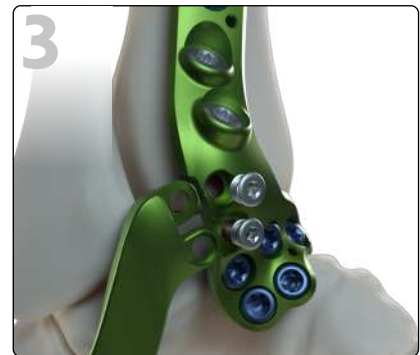

Assemble the extension on the plate then lock the assembly with the two fixing screws (RATxB1-VIS) using the T8 screwdriver (ANC575).



Perform a second short incision following the conventional calcaneal surgical approach.

Insert the Ø3.0 mm threaded guide gauge (ANC847) into the non-locking hole. Drill using the Ø3.0 mm drill bit (ANC852) and determine the appropriate screw length. Insert the standard Ø4.0 mm non-locking screw (CT4.0LxxD) using the T20 screwdriver (ANC854).



Insert the remaining locking screws (SOT4.0LxxD).



FINAL RESULT.

Implants references.

N.B: All the implants are also available in a sterile version. An «-ST» is added to the end of the reference.
 Ex. : "RATGASS-ST" stands for Anterior plate - Ankle arthrodesis - Left - Short - Sterile.

Anterior plates

Ref.	Description	Length
RATGASS	Anterior plate - Ankle arthrodesis - Left - Short	L62.6 mm
RATDASS	Anterior plate - Ankle arthrodesis - Right - Short	L62.6 mm
RATGA0	Anterior plate - Ankle arthrodesis - Left - Size 0	L82.3 mm
RATDA0	Anterior plate - Ankle arthrodesis - Right - Size 0	L82.3 mm
RATGA1	Anterior plate - Ankle arthrodesis - Left - Size 1	L84.4 mm
RATDA1	Anterior plate - Ankle arthrodesis - Right - Size 1	L84.4 mm



Anterior plates - Narrow

Ref.	Description	Length
RATGAN	Anterior plate - Ankle arthrodesis - Left - Narrow - Size 1	L54.2 mm
RATDAN	Anterior plate - Ankle arthrodesis - Right - Narrow - Size 1	L54.2 mm



Anterolateral and Calcaneal lateral extension plates

Ref.	Description	Length
RATGB0	Anterolateral plate - Ankle arthrodesis - Left - Size 0	L92 mm
RATDB0	Anterolateral plate - Ankle arthrodesis - Right - Size 0	L92 mm
RATGB1	Anterolateral plate - Ankle arthrodesis - Left - Size 1	L113.2 mm
RATDB1	Anterolateral plate - Ankle arthrodesis - Right - Size 1	L113.2 mm
RATGB1-E1	Anterolateral plate extension - Ankle arthrodesis - Left - Size 1	L70.4 mm
RATDB1-E1	Anterolateral plate extension - Ankle arthrodesis - Right - Size 1	L70.4 mm

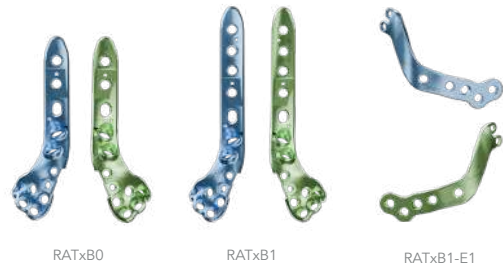

Posterior plates

Ref.	Description	Length
RATGT1	Posterior TT plate - Ankle arthrodesis - Left - Size 1	L94.4 mm
RATDT1	Posterior TT plate - Ankle arthrodesis - Right - Size 1	L94.4 mm
RBTGT1	Posterior TTC plate - Ankle arthrodesis - Left - Size 1	L107.2 mm
RBTDT1	Posterior TTC plate - Ankle arthrodesis - Right - Size 1	L107.2 mm
RCTGT1	Posterior TTC plate - Straight - Ankle arthrodesis - Left - Size 1	L107.2 mm
RCTDT1	Posterior TTC plate - Straight - Ankle arthrodesis - Right - Size 1	L107.2 mm



Ø4.0 mm locking screws*

Ref.	Description
SOT4.0L12D to SOT4.0L50D	Locking screw - Ø4.0 mm - L12 to 50 mm (2 mm increments)
SOT4.0L50D to SOT4.0L60D	Locking screw - Ø4.0 mm - L50 to 60 mm (5 mm increments)

*Blue anodized



Ø4.0 mm non-locking screws*

Ref.	Description
CT4.0L12D to CT4.0L50D	Non-locking screw Ø4.0 mm - L12 to 50 mm (2 mm increments)
CT4.0L50D to CT4.0L60D	Non-locking screw Ø4.0 mm - L50 to 60 mm (5 mm increments)

*Not anodized



Ø6.5 mm lag screws*

Ref.	Description
QT6.5L30D-ST to QT6.5L35D-ST	Ø6.5 mm lag screw - L30 to 35 mm - STERILE**
QT6.5L40D to QT6.5L100D	Ø6.5 mm lag screw - L40 to 100 mm (5 mm increments)

*Not anodized

**These screws are only provided on specific request



Ø6.5 mm non-locking screws*

Ref.	Description
CT6.5L30D-ST to CT6.5L35D-ST	Ø6.5 mm non-locking screw - L30 to 35 mm - STERILE**
CT6.5L40D to CT6.5L100D	Ø6.5 mm non-locking screw - L40 to 100 mm (5 mm increments)

*Not anodized

**These screws are only provided on specific request



Extension fixation screw*

Ref.	Description
RATxB1-VIS	Fixation screw - Anterolateral plate extension - Ankle arthrodesis
RATxB1-VIS-ST	Fixation screw - Anterolateral plate extension - Ankle arthrodesis - STERILE**

*Not anodized

**These screws are only provided on specific request



Additional implants for stand-alone screws*

Ref.	Description
H2.6QT6.5L40D-ST to H2.6QT6.5L120D-ST	Ø6.5 mm compressive screw - cannula Ø2.6 - short thread - STERILE - L40 to L120 mm (5 mm increments)
H2.6JT6.5L45D-ST to H2.6JT6.5L120D-ST	Ø6.5 mm compressive screw - cannula Ø2.6 - long thread - STERILE - L45 to L120 mm (5 mm increments)
H2.6CT6.5L40D-ST to H2.6CT6.5L120D-ST	Ø6.5 mm standard cortical screw - cannula Ø2.6 - full thread - STERILE - L40 to L120 mm (5 mm increments)

*For more information, see the Activ Screw range sales brochure.

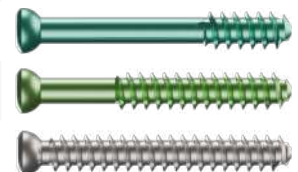

Instruments references.

Instrumentation contents

#	Ref.	Description	Qty	Use
01	ANC350	Ø4.5 mm AO quick coupling handle - Size 1	1	M
02	ANC351	Ø4.5 mm AO quick coupling handle - Size 2	1	M
03	ANC575	T8 quick coupling screwdriver	1	M
04	ANC845	Ø6.0 mm countersink - cannula Ø1.4 mm	1	M/A
05	ANC847	Ø3.0 mm threaded guide gauge for Ø4.0 mm screws	2	M
06	ANC848	Ø4.7 mm bent drill guide for Ø6.5 mm screws	2	M
07	ANC851	Ø4.7 mm quick coupling drill bit - L195 mm	2	A
08	ANC852	Ø3.0 mm quick coupling drill bit - L 195 mm	2	A
09	ANC853	Length gauge for Ø6.5 mm screws	1	M
10	ANC854	T20 prehensor screwdriver	2	M/A
11	ANC855	Ø3.0 mm drill guide for Ø6.5 mm screws	2	M
12	ANC856	Length gauge for Ø4.0 mm screws	1	M
13	33.0216.150	Pin Ø1.6 - L150 mm	6	A
14	33.0225.180	Pin Ø2.5 - L180 mm	6	A

Container references

#	Ref.	Description	Qty
15	ANC895/B	Activ Fuse set - Base	1
16	ANC895/C	Activ Fuse set - Lid	1
17	ANC895/I	Activ Fuse set - Insert	1
18	ANC895/M1	Activ Fuse set - Module 1 - 8 slots	9
19	ANC895/R1	Activ Fuse set - Ø4.0 mm Screw rack	1
20	ANC895/R2	Activ Fuse set - Ø6.5 mm Screw insert	1

Optional instrumentation

Ref.	Description	Use
ANC1137	Ø4.5 mm cannulated AO quick coupling straight handle with ratchet - Size 2	M

REMOVAL KIT

If you have to remove Activ Fuse implants, make sure to order the Newclip Technics removal set which includes the following instruments:

- ANC042: Mini set - Base
- ANC351: Ø4.5 mm AO quick coupling handle - Size 2
- ANC575: T8 quick coupling screwdriver
- ANC980: T20 screwdriver with AO quick coupling system

To remove any of the Activ Fuse plates, first loosen all the screws without completely removing them (this prevents rotation of the plate when removing the last screw). Finally, completely remove all screws and the plate.

Additional instruments for stand-alone screws*

Ref.	Description	Qty	Use
ANC442	Ø11 mm cannulated quick coupling straight handle	1	M
ANC443	Ø11 mm cannulated quick coupling T-handle	1	M
ANC727	Ø4.6 mm drill bit - cannula Ø2.6 mm - L260 mm	1	A
ANC730	2 in 1 : T25 screwdriver Ø2.6 mm cannulated - Ø8.0 mm countersink	2	M/A
ANC733	Length gauge for pin Ø2.5 mm - L210 mm	1	M
ANC735	Ø2.5 mm pin guide	1	M
ANC754	Soft tissue protection sleeve	1	M
ANC1585	Jacobs cannulated quick coupling adaptor for Ø11 mm instruments	1	A
33.0225.230	Pin Ø2.5 - L230 mm	6	A

*For more information, see the Activ Screw range sales brochure.

M : Usable only manually
 A : Usable only while connected to active device
 M/A : Usable manually or while connected to active device

PSI instrumentation

Ref.	Description
ANC042	Mini set - Base
ANC716	Patient specific cutting guide for ankle arthrodesis
ANC1350	Ø2.2 mm - L10 mm holding plot
33.0222.200	Pin Ø2.2 - L200 mm



Compatible with patient-specific cutting guides (PSI)

Please contact your NEWCLIP TECHNICS representative if you have any questions about the availability of NEWCLIP TECHNICS products in your area.

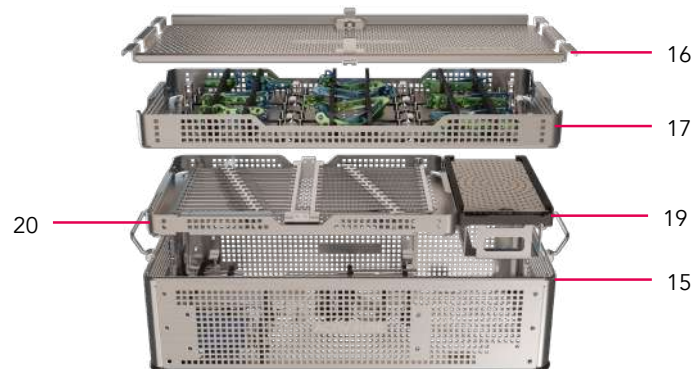
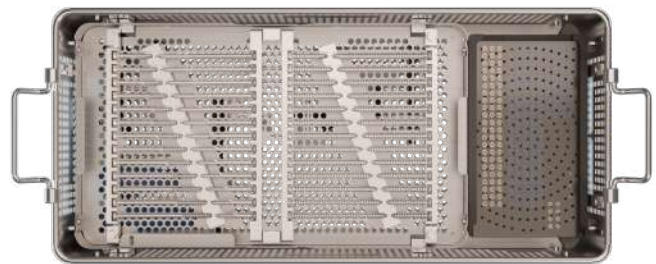
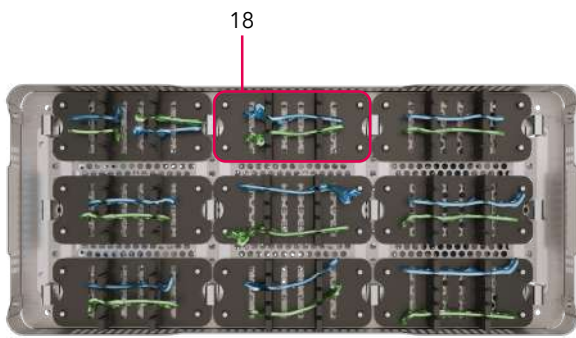
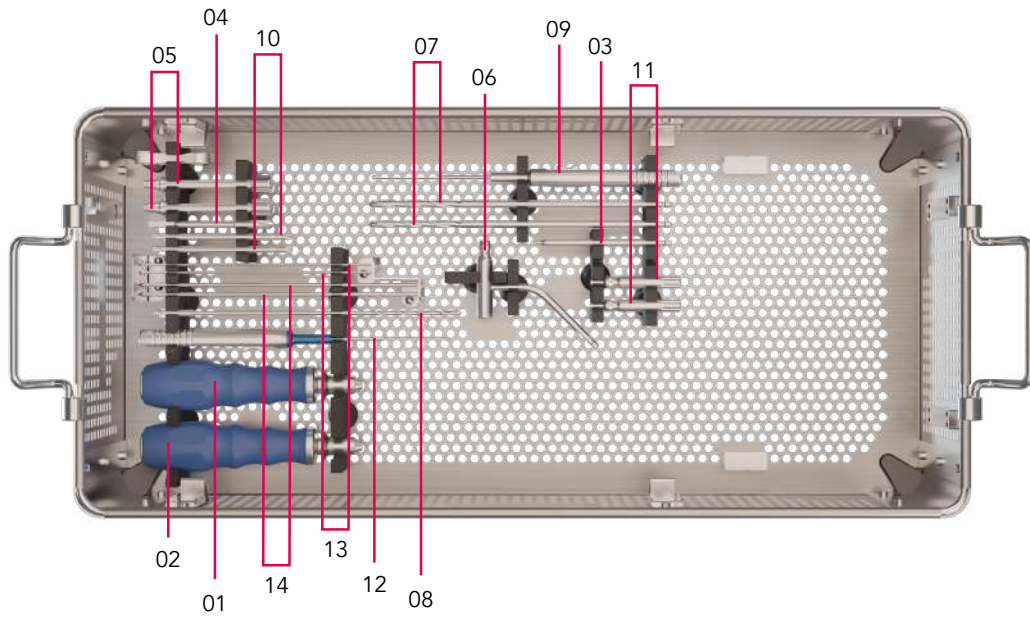

This information is intended to demonstrate the Newclip Technics portfolio of medical devices. Always refer to the package insert, product label and/or user instructions including cleaning and sterilization before using any Newclip Technics product. These products must be handled and/or implanted by trained and qualified staff who have read the instructions before use. A surgeon must always rely on her or his own professional clinical judgement when deciding whether to use a particular product when treating a particular patient. Product availability is subject to the regulatory or medical practices that govern individual markets. Please contact your Newclip Technics representative if you have questions about the availability of Newclip Technics products in your area.

Manufacturer: Newclip Technics - Brochure EN - Activ Fuse - Ed.11 - 04/2026 - Medical devices: class IIb - CE1639 SGS BE. Read labelling and instructions before the use of Newclip Technics medical devices. These products must be handled and/or implanted by trained and qualified staff who have read the instructions before use. Non-contractual pictures.
 Newclip Technics - 45 rue des Garottières - 44115 Haute Goulaine, France. Our subsidiaries: Newclip USA - Newclip Australia - Newclip Germany - Newclip Japan - Newclip Iberia - Newclip Belgium - Newclip Italia.

newcliptechnics.com

